

Link Touch

LNK-T10-IP-SM



Product Overview

Thank you for purchasing a Link Touch display.

Based on the DS7610 10.1" Android-powered industrial touch screen

- Designed for displaying the web interface of your Building Management System (BMS/BAS)
- Equipped with both Ethernet IP and WiFi connectivity
- Built-in LoRaWAN® Gateway for AIoT Insights
- NFC Enabled Application for LoRaWAN sensor commissioning
- Plug-and-play PoE, DC power, or Type C power supply available, NOT included
- HTML5 compatible
- Benefits from our preinstalled Innon application

The Innon application allows you to configure multiple devices in one go. It also enables you to secure your Link Touch via a secure password. Please consult the manual by visiting support.innon.com. The Link app default configuration password is **link1234**.

LNK-T10-IP-SM connections

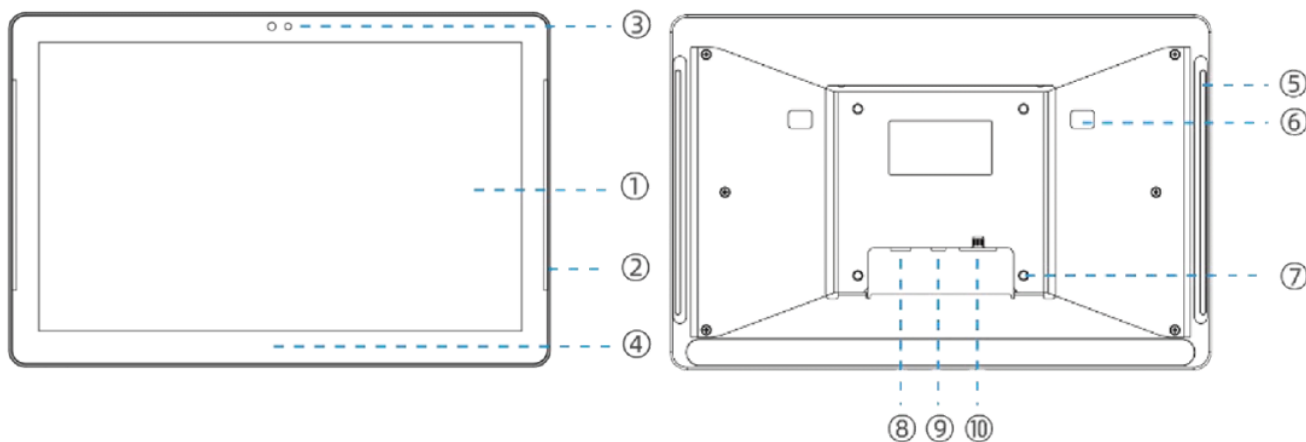

1)	Touch screen	6)	Wall mount bracket holes
2)	Front RGB LED light strips	7)	75x75 VESA mount screw holes
3)	Light and proximity sensors	8)	Type C USB port (can be used also for power)
4)	NFC area	9)	DC power jack
5)	Back RGB LED light strips	10)	RJ45 ethernet port (PoE enabled)

Wall Installation

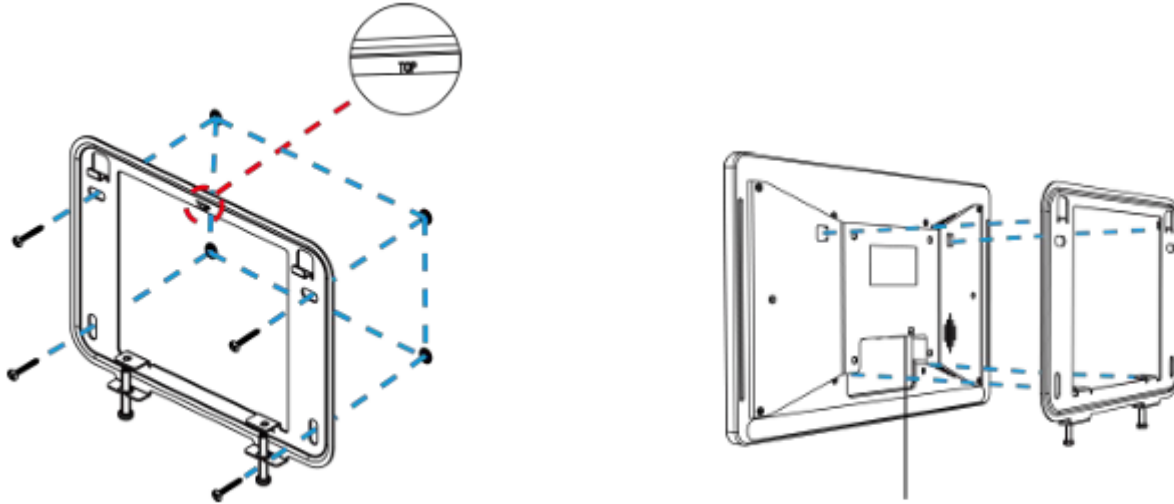

Technical Specification

Screen size	10.1 inch TFT LCD Touch Screen
Aspect ratio	16:10
Resolution	1280 x 800
Contrast	1000:1
Luminance	300 Cd/m ²
Active area	216.58 x 135.36 mm
Screen-to-body ratio	74.88%
CPU configuration	Quad core ARM Cortex A55
Internal memory	eMMC 16 GB
RAM	2 GB DRAM
OS	Android 11.0
WiFi	IEEE 802.11 b/g/n 2.4 GHz
	IEEE 802.11 a/n/ac 5 GHz
Bluetooth	Bluetooth 5.0
Touch type	Capacitive Touch Screen
I/O	USB 1x Type C OTG or Host Mode
	Ethernet 1x RJ45 10/100/1000 Mbps (PoE)
	Power jack connection 1x 3.5 x 1.35 mm barrel

Speaker	1.5 W
Proximity sensor	1 m distance (max)
Light sensor	5 brightness level adjustment
LED	RGB side LED indicators, stepless adjustment
Power supply	802.3af PoE
	12V/1A DC jack connector
	5V/2A USB type C port
Operating temperature and humidity	Temperature: -20°C to +50°C (-4°F to 122°F)
	Humidity: 0 to 95 %RH (non-condensing) below 25°C/77°F
Ingress Protection	IP30
Dimensions	245 (L) x 160 (H) x 18 (D) mm
Weight	0.65 kg (without bracket), 0.7 kg (with bracket)
Installation	Wall mounting, 3M tape mounting, VESA (75 x 75 mm optional)
Colour and material	Black, Metal

Important notes:

1. The back RGB LED light strips will need the blackout cover removed to be used
2. Please do not operate the reset button placed near the USB type C connection without consulting the manual carefully or checking with Innon. Operating the reset button wrongly might brick the device

Other instructions:

For support go to www.innon.com/support

To setup your Link Touch please consult

the manual at support.innon.co.uk

E: support@innon.co.uk T: +44 (0) 20 3953 4100